

OrbiPlateTM Post Installed Design Guide

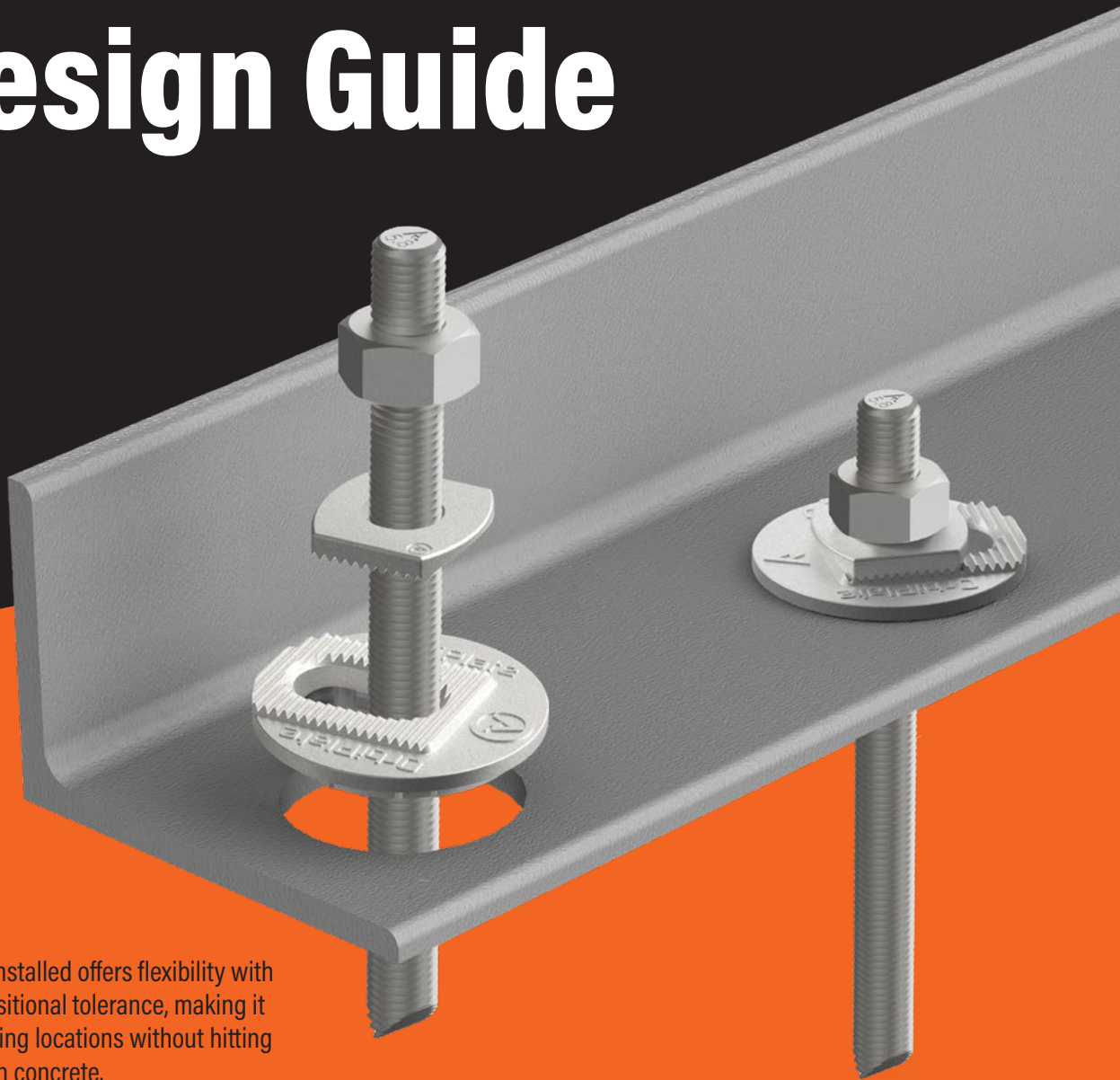

OrbiPlateTM Post Installed offers flexibility with rotational and positional tolerance, making it easier to find drilling locations without hitting reinforcing bars in concrete.

For more information on
our products call
AU 1300 780 063

Applications

The Ramset™ OrbiPlate™ is a versatile solution for a wide range of applications, including straight panel-to-panel connections, corner panel-to-panel connections, roof beam-to-panel connections, raker angle-to-panel connections, and column-to-panel connections. It effectively addresses the common challenge of aligning holes — a task that is often time-consuming, costly, and structurally inadequate with traditional methods.

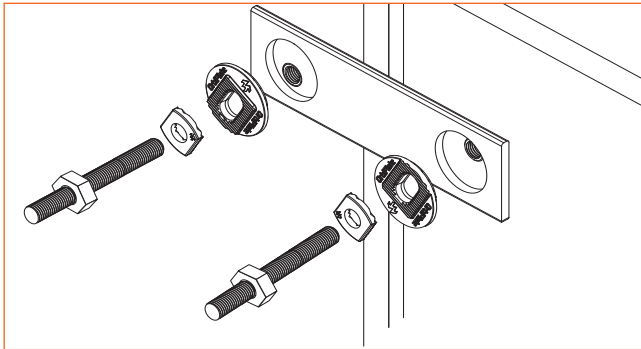

Straight panel to panel connection

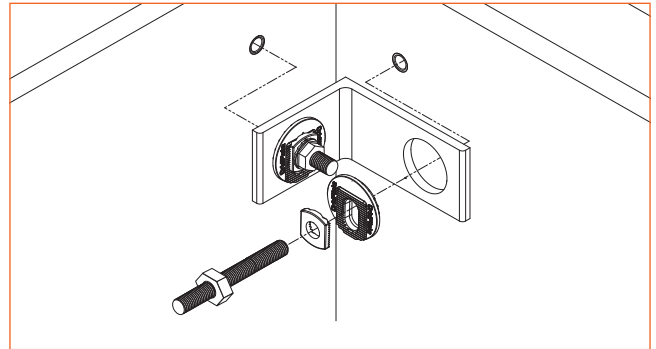

Corner panel to panel connection

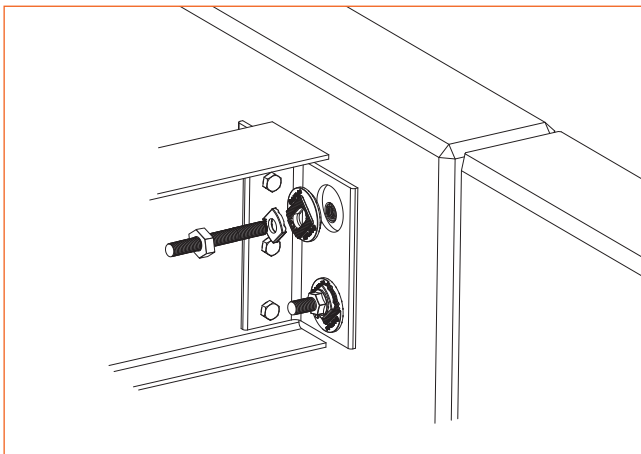

Roof beam to panel connection

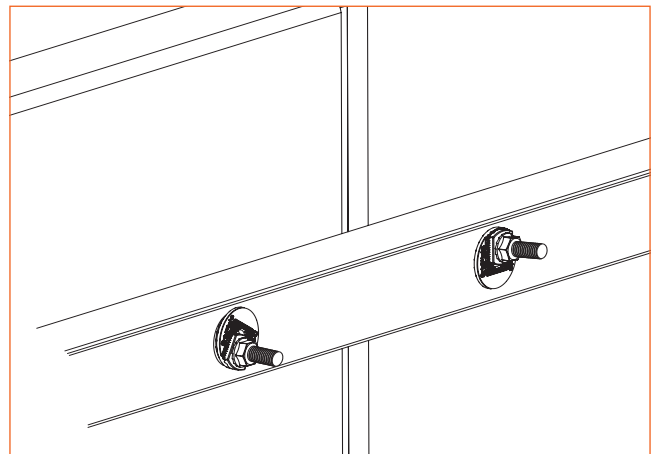

Raker angle to panel connection

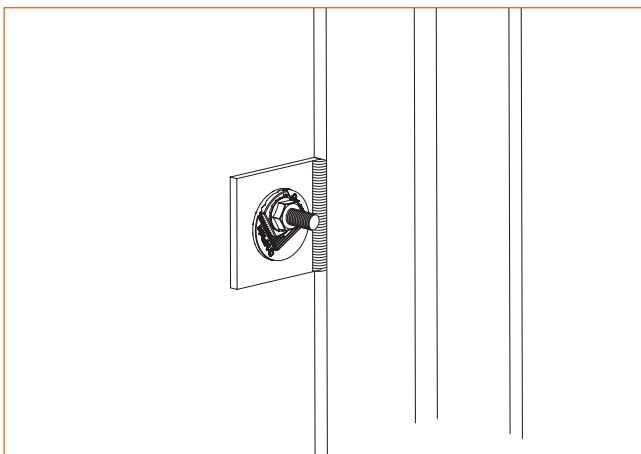

Column to panel connection

Benefits

Ramset Post-Installed OrbiPlate is a smart solution to avoid the challenges of rebar interference while keeping the project efficient and cost-effective. It's a great way to ensure structural integrity and avoid additional costs related to fixture rework and the time delays from redoing drilled holes.

When anchoring into heavily reinforced concrete it is common to encounter rebar when drilling. This can be a serious issue, both for the integrity of the structure and for the work process itself. Drilling through rebar risks compromising the concrete's strength, which could affect the building's overall structural integrity. Additionally, drilling through rebar can be tough on tools, increasing wear and tear and leading to greater costs in the long run due to the need for specialized, stronger bits.

The alternative is to fill the hole with a chemical adhesive, wait for it to cure, and then drill a new hole adjacent to the original hole. However, this approach is time-consuming, involves extra material costs, and requires modifications to the steel fixture, making the process more complicated and expensive.

Using a post-installed OrbiPlate allows the installer to avoid the need to rework rebar by first scanning the concrete and marking out the rebar locations. This step helps the installer avoid drilling directly into the rebar, which can prevent damage to the structure and tools.

The OrbiPlate's 20mm tolerance around the original hole location allows for some flexibility in positioning the new holes. If the installer detects rebar in the original planned location, they can simply shift the hole within that 20mm margin without needing to drastically alter the installation plan. This flexibility saves time and avoids having to redo the work.

If rebar is encountered, rather than continuing to drill through it, the installer can fill the hole with a chemical adhesive. This ensures that the structural integrity of the concrete is not compromised. Once the adhesive cures, the installer can then drill a new hole within the 20mm tolerance allowed by the Orbi plate, preserving the original fixture alignment without any need to modify or rework the steel fixture itself.

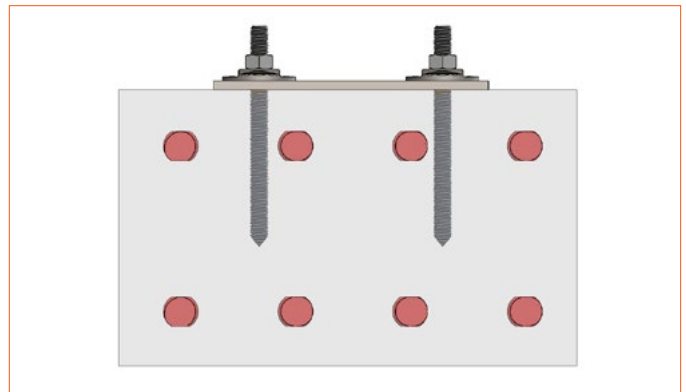
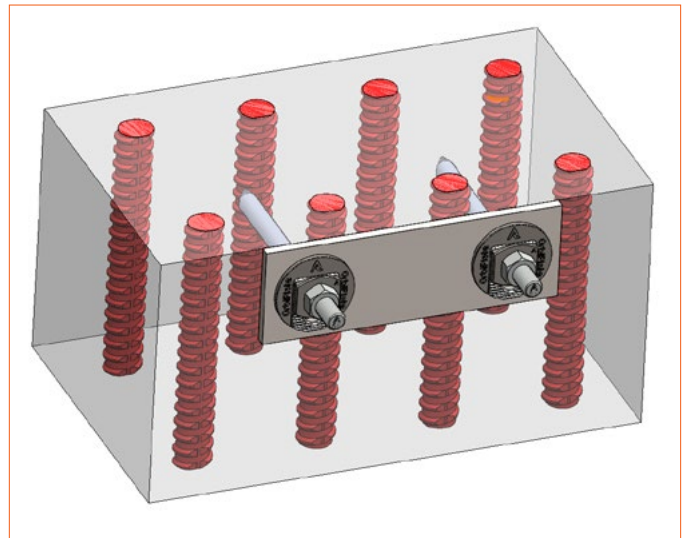
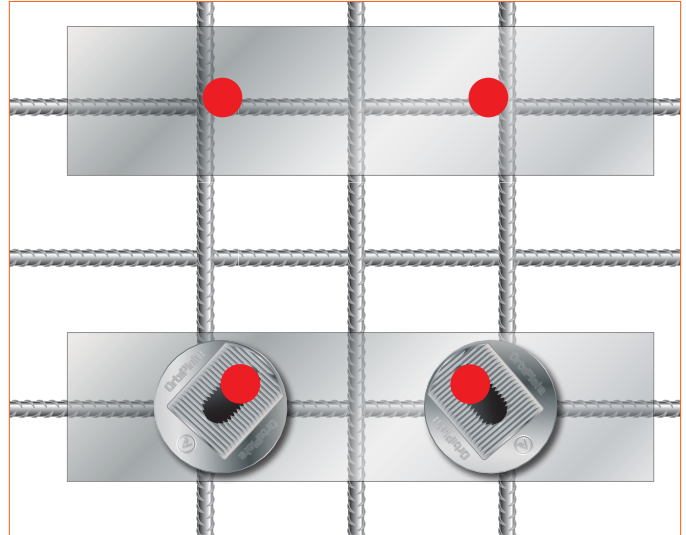

Example of a concrete column to give perspective of the rebar density.

OrbiPlate™ & ChemSet™ Anchor Stud M20 HDG Kit with Reo 502™ PLUS

General Information

Product

OrbiPlate™ Post Installed offers flexibility with rotational and positional tolerance, making it easier to find drilling locations without hitting reinforcing bars in concrete.

Compliance

European Technical Assessment (option 1) - ETA-18/0675

Design according to:

- AS5216 (formerly TS101)
- AS1170.4 - Earthquake Actions
- EN1992-4 (formerly ETAG001 Annex C, E & TR045)
- Use enclosed data for simplified calculation method

Use Ramset™ iExpert Anchor Software for optimised calculation or where a greater range of anchor layout detail is needed.

Feature

- A large washer with an elongated slot surrounded by teeth that lock the smaller washer in place, allowing positioning of the Anchor Stud with up to 20mm misalignment.

Advantages

- Provides 20mm positional tolerance.
- Fine positional adjustment.
- No rotation under shear load.

Benefits

- High structural capacity.
- Allows fine positional adjustment.
- Avoids misalignment delays and call outs.
- No hot work required on site.

Installation

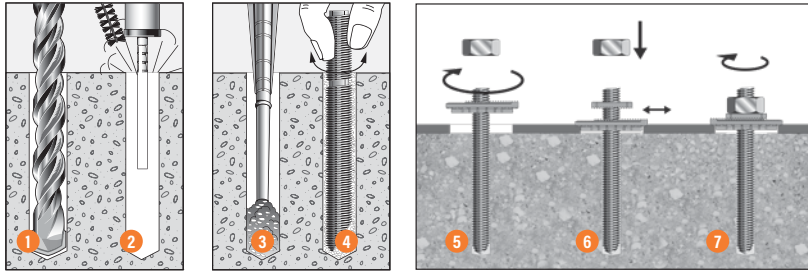

1. Drill recommended diameter and depth hole.
2. **Important:** Use Ramset™ Dustless Drilling System to ensure holes are clean. Alternatively clean dust and debris from hole with stiff wire or nylon brush and blower in the following sequence: blow x 2, brush x 2, blow x 2, brush x 2, blow x 2.
3. Dispense adhesive to waste until colour is uniform light grey (2-3 trigger pulls). Insert mixing nozzle to bottom of hole. Fill hole to 3/4 the hole depth slowly, ensuring no air pockets form.
4. Insert the supplied Ramset™ ChemSet™ Anchor Stud to bottom of hole while turning.
5. (TWIST IT) Place the large washer in the 70mm fixture hole and rotate until the slot lines up with the M20 ChemSet Anchor Stud.
6. (SLIDE IT) Move the small washer along slot until it aligns with the M20 ChemSet Anchor Stud.
7. (FIX IT) Attach the nut and tighten to the specified torque.



Performance Related



Material Specification



Installation Related

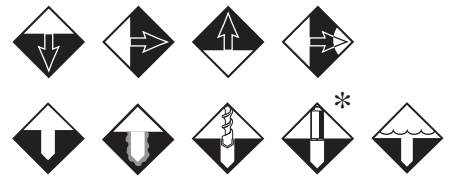

Principal Applications

- Panel to panel fixing
- Raker Angles
- Roof beams to walls
- Steel column to panels

Recommended Installation Temperatures

	Minimum	Maximum
Substrate	5°C	40°C
Adhesive	10°C	40°C

Service Temperature Limits

-40°C to 70°C

Temperature of base material	Cartridge Temperature	Gel Time	Curing time in dry and wet concrete
5°C	Minimum 10°C	300 min	24 h
10°C	10°C	150 min	18 h
15°C	15°C	40 min	12 h
20°C	20°C	25 min	8 h
25°C	25°C	18 min	6 h
30°C	30°C	12 min	4 h
40°C	40°C	6 min	2 h

Note: Cartridge temperature minimum +10°C

Note

*Seismic Performance of cored & oversized holes was not included in the ETAG test program. Performance data of cored holes only applies to cracked and uncracked concrete based on the latest European Technical Assessment ETA 18/0675.

OrbiPlate™ & ChemSet™ Anchor Stud M20 HDG Kit with Reo 502™ PLUS Combination

The following design information is for the OrbiPlate™ & ChemSet Anchor Stud Kit when used in combination with Ramset™ ChemSet™ Reo 502™ PLUS. This design information is not applicable if OrbiPlate™ is used with other adhesive anchor systems as a reduction in capacity can be expected.

Installation and Performance Details:

Non-Cracked Concrete Design

Anchor size, d_b (mm)	Drilled hole diameter, d_h (mm)	OrbiPlate™ Part Number	Fixture hole diameter, d_f (mm)	Anchor effective depth, h_n (mm)	Tightening torque, T_t (Nm)	Optimum dimensions*		Concrete substrate thickness, b_m (mm)	Reduced Characteristic Capacity#					
						Anchor spacing, a_c (mm)	Edge distance, e_c (mm)		Grade 5.8 Steel Studs		Non-Cracked Concrete			
									Shear, ϕV_{us} (kN)	Tension, ϕN_{us}^{***} (kN)	Tension, ϕN_{uc} (kN)**			
						Concrete Compressive Strength, f_c								
20 MPa	32 MPa	40 MPa												
M20	22	ORB2020PIAGH	70 ± 1	100	120	300	150	144	49.9	81.3	32.8	41.5	46.5	
				150		450	225				190	60.2	76.2	80.7
				170		510	255				214	72.6	88.9	91.4

*Note: For shear loads acting towards an edge or where these optimum dimensions are not achievable, please use the simplified strength limit state design process to verify capacity.

**Note: Reduced characteristic ultimate concrete tensile capacity = ϕN_{uc} where $\phi = 0.67$ and N_{uc} = Characteristic ultimate concrete tensile capacity.

For conversion to Working Load Limit MULTIPLY ϕN_{uc} x 0.5

***Note: Reduced characteristic ultimate steel tensile capacity = ϕN_{us} where $\phi = 0.67$ and N_{us} = Characteristic ultimate steel tensile capacity.

For conversion to Working Load Limit MULTIPLY ϕN_{us} x 0.67 for Gr 5.8

#Note: Design Tensile Capacity ϕN_{ur} = minimum of ϕN_{uc} and ϕN_{us}

For Cracked Concrete performance, please use the simplified strength limit state design process to verify capacity.

Data is based on a Service temperature limit of -40°C to +70°C

All data relevant for Dry, Wet and Flooded Holes.

Seismic Design

Anchor size, d_b (mm)	Drilled hole diameter, d_h (mm)	OrbiPlate™ Part Number	Fixture hole diameter, d_f (mm)	Anchor effective depth, h_n (mm)	Tightening torque, T_t (Nm)	Optimum dimensions*		Concrete substrate thickness, b_m (mm)	Reduced Characteristic Capacity										
						Anchor spacing, a_c (mm)	Edge distance, e_c (mm)		Grade 5.8 Steel Studs				Seismic C1 & C2 Cracked Concrete tensile capacity, $N_{Rd,s,seis}^0$ (kN)**						
									Shear, $V_{Rd,s,seis}$ (kN)#		Tension, $N_{Rd,s,seis}$ (kN)***		Concrete Compressive Strength, f_c						
						C1			C2		C1		C2		C1		C2		
M20	22	ORB2020PIAGH	70 ± 1	100	120	300	150	144	7.3	7.3	82	82	18.7	12.3	19.5	12.8	20.1	13.2	
				150		450	225						190	35.3	23.3	36.8	24.3	37.9	25.0
				170		510	255						214	40.3	27.2	41.9	28.3	43.1	29.1

* For anchor spacings or edge distances less than the minimum, please refer to the simplified strength limit state design process to verify capacity.

** Tension values are based on service temperature limits -40°C to +70°C only. If service temperature limits is beyond this range please contact Ramset Engineer.

** Note: Seismic Cracked concrete combined pull-out and concrete cone resistance, tension = $N_{Rd,s,seis}^0 = \alpha_{seis} N_{Rk,s,seis}^0 / \gamma_{Mse}$ where $\gamma_{Mse} = 1.5$

***Note: Seismic Cracked Concrete steel resistance, tension = $N_{Rd,s,seis} = \alpha_{seis} N_{Rk,s,seis} / \gamma_{Ms}$ (kN) where $\gamma_{Ms} = 1.5$ (Grade 5.8 steel)

Note: Shear Data includes annular gap reduction factor of 0.5

For optimised performance data, please use Ramset iExpert Anchoring Software.

Description And Part Numbers

OrbiPlate™ Kit

Anchor size, d_b (mm)	Description		Part No.
			Gal
M20 x Serrated Plates	Washer OD (mm)	Fixture hole (mm)	ORB2020PIAGH
	80	70 ± 1	
M20 x 240	ChemSet Anchor Stud Galvanised		

ChemSet™ Adhesive Anchoring System Design

Description	Size	Part No.
ChemSet Reo502 PLUS	600ml	RE0502P600

Engineering Properties

OrbiPlate™ and ChemSet™ Anchor Stud Combination

Anchor Stud Size, d_b	Overall Length, L (mm)	Effective Length, L_e (mm)	Max Fixture Thickness, t (mm)	Stress Area, A_s (mm ²)	Grade 5.8 Steel Studs		Section Modulus, Z (mm ³)
					Yield Strength, f_y (MPa)	Carbon Steel UTS, f_u (MPa)	
M20	240	225	32	232.4	420	520	540.9

Strength Limit State Design / OrbiPlate™ with M20 ChemSet™ Anchor Stud with Reo 502™ PLUS

STEP 1

Select anchor to be evaluated

Table 1a - Indicative combined loading - interaction diagram

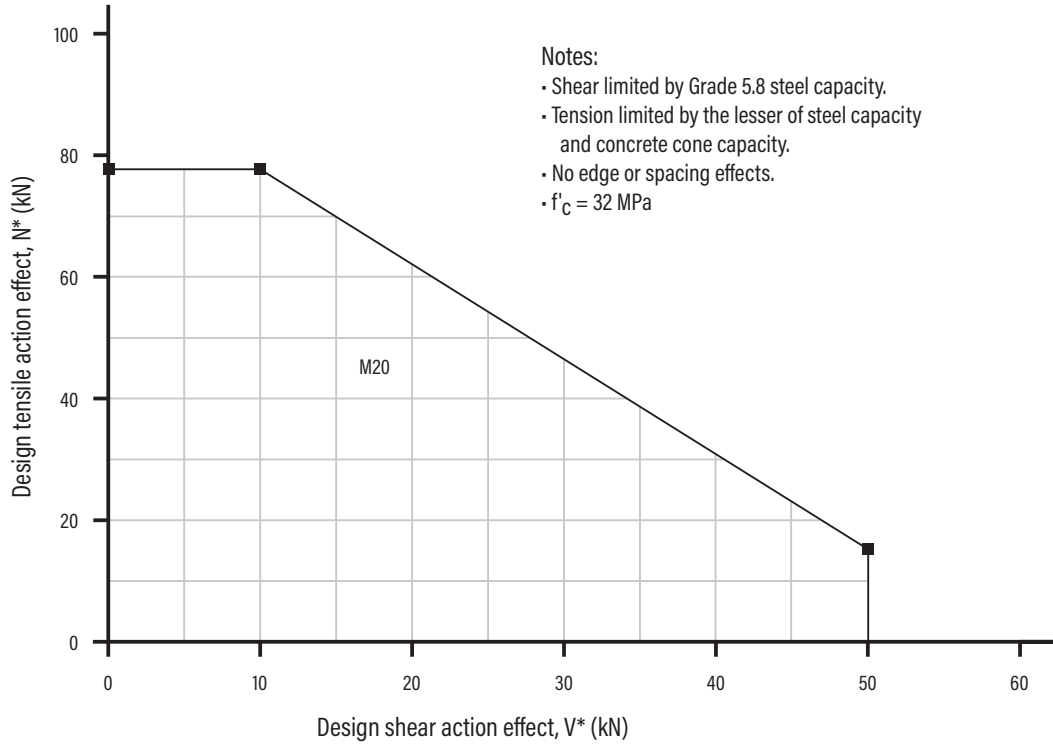

Table 1b - Absolute minimum edge distance and anchor spacing values, e_m and a_m (mm)

Anchor Stud Size, d_b	M20
e_m	50
a_m	50

Step 1c Calculate anchor effective depth, h (mm)

Effective depth, h (mm)
 Preferred $h = h_n$ otherwise,
 $h = L_e - t$
 t = total thickness of material(s) being fastened.

Substrate thickness b_m (mm)
Anchor Stud Size (mm)
M20
$h + (2 \times d_b)$

CHECK POINT 1

Anchor size determined, absolute minima compliance achieved.

Strength Limit State Design / OrbiPlate™ with M20 ChemSet™ Anchor Stud with Reo 502™ PLUS

STEP 1

Verify concrete tensile capacity - per anchor

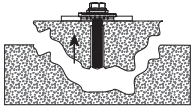

Table 2a - Reduced characteristic ultimate concrete tensile capacity, ϕN_{uc} (kN), $\phi_c = 1/1.5 = 0.67$, $f'_c = 32$ MPa

Fixing System	OrbiPlate™ with M20 ChemSet™ Galvanised Anchor Stud installed with Reo502™ PLUS										
Effective depth h, (mm)	100	150	160	170	180*	200*	240*	280*	320*	350*	400*
Bond - ϕN_{ucp} (kN)	52.3	78.4	83.6	88.9	94.1	104.6	125.5	146.4	167.3	183.0	209.1
Concrete Cone - ϕN_{ucc} (kN)	41.5	76.2	84.0	91.9	100.2	117.3	154.2	194.4	237.5	271.6	331.9

*Note: For effective depth 180mm and greater please use typical threaded rod with minimum grade 5.8 and cut to length.

Table 2a-2 - Cracked Concrete or Seismic effect, tension, $X_{n,cr,seis}$

Fixing System		OrbiPlate™ with M20 ChemSet™ Galvanised Anchor Stud installed with Reo502™ PLUS			
Condition		Non-Cracked Concrete	Cracked Concrete	Seismic Cracked Concrete	
				C1	C2
$X_{n,cr,seis}$	for Bond $\phi N_{uc} = \phi N_{ucp}$	1.00	0.75	0.47	0.31
	for Concrete Cone $\phi N_{uc} = \phi N_{ucc}$	1.00	0.70	0.59	0.59

Calculate ϕN_{urc} for both ϕN_{ucp} and ϕN_{ucc} then choose the minimum - Refer to Checkpoint 2

Table 2b - 1 - Concrete service temperature limits effect, tension, X_{ns}

Service temperature (°C) -40 °C to +70 °C		
X_{ns}	for Bond $\phi N_{uc} = \phi N_{ucp}$	1.00
	for Concrete Cone $\phi N_{uc} = \phi N_{ucc}$	1.00

Table 2b - 2 - Concrete compressive strength effect, tension, X_{nc}

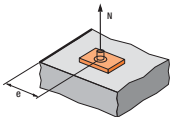

$X_{ne} = 0.25 + 0.5 \cdot (e/h)$
Where $e_m \leq e \leq e_c$

$e_c = 1.5 \cdot h$

Note: Tabled values are based on the nominal effective depth, h shown in the installation details. For other values of X_{ne} please use equation shown above.

Table 2c - Edge distance effect, tension, X_{ne}

Fixing System	OrbiPlate™ with M20 ChemSet™ Galvanised Anchor Stud installed with Reo502™ PLUS										
Edge distance, e (mm)	50	65	70	80	100	115	135	165	187	255	
Effective Depth, h (mm)											
100	0.50	0.58	0.60	0.65	0.75	0.83	0.93	1.00	1.00	1.00	
150	0.42	0.47	0.48	0.52	0.58	0.63	0.70	0.80	0.87	1.00	
170	0.40	0.44	0.46	0.49	0.54	0.59	0.65	0.74	0.80	1.00	
200	0.38	0.41	0.43	0.45	0.50	0.54	0.59	0.66	0.72	0.89	
280	0.34	0.37	0.38	0.39	0.43	0.46	0.49	0.54	0.58	0.71	

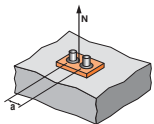

$X_{na} = 0.5 + a/(6 \cdot h)$

Where $a_m \leq a \leq a_c$

$a_c = 3 \cdot h$

Note: Tabled values are based on the nominal effective depth, h shown in the installation details. For other values X_{na} please use equation shown above.

Table 2d - Anchor spacing effect, tension, X_{na}

Fixing System	OrbiPlate™ with M20 ChemSet™ Galvanised Anchor Stud installed with Reo502™ PLUS										
Anchor spacing, a (mm)	50	65	85	100	125	150	200	270	375	510	
Effective Depth, h (mm)											
100	0.58	0.61	0.64	0.67	0.71	0.75	0.83	0.95	1.00	1.00	
150	0.56	0.57	0.59	0.61	0.64	0.67	0.72	0.80	0.92	1.00	
170	0.55	0.56	0.58	0.60	0.62	0.65	0.70	0.76	0.87	1.00	
200	0.54	0.55	0.57	0.58	0.60	0.63	0.67	0.73	0.81	0.93	
280	0.53	0.54	0.55	0.56	0.57	0.59	0.62	0.66	0.72	0.80	

CHECK POINT 2

Design reduced ultimate tensile capacity, ϕN_{urc}

$\phi N_{urc} = \text{minimum of } \phi N_{ucp} \cdot X_{n,cr,seis} \cdot X_{ns} \cdot X_{nc} \cdot X_{ne} \cdot X_{na} \text{ and } \phi N_{ucc} \cdot X_{n,cr,seis} \cdot X_{ns} \cdot X_{nc} \cdot X_{ne} \cdot X_{na}$

Strength Limit State Design / OrbiPlate™ with M20 ChemSet™ Anchor Stud with Reo 502™ PLUS

STEP 3 Verify anchor tensile capacity - per anchor



Table 3a - Reduced characteristic ultimate steel tensile capacity, ϕN_{us} (kN) where $\phi_n = 0.67$ for Gr 5.8

Anchor Size, d_b	M20
ChemSet™ Anchor Stud Grade 5.8 Galv. Carbon Steel	81.3

Note: Tensile Steel Capacity is also applicable for Seismic Category C1 and C2 conditions.

CHECK POINT 3

Design reduced ultimate tensile capacity, ϕN_{ur}

$\phi N_{ur} = \text{minimum of } \phi N_{urc}, \phi N_{us}$

Check $N^* / \phi N_{ur} \leq 1$,

if not satisfied return to step 1

Strength Limit State Design / OrbiPlate™ with M20 ChemSet™ Anchor Stud with Reo 502™ PLUS

STEP 4 Verify concrete shear capacity - per anchor

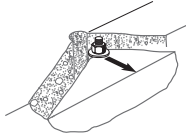

Table 4a - Reduced characteristic ultimate concrete edge shear capacity, ϕV_{uc} (kN), $\phi = 1/1.5 = 0.67$ $f'_c = 32$ MPa

Anchor Size, d_s	M20			
	100	150	170	180-400
Effective depth, h (mm)				
Edge distance, e_m (mm)				
50	7.2	8.2	8.5	8.7

Table 4a - 1 - Cracked Concrete or Seismic effect, tension, $X_{v,cr,seis}$

Fixing System	OrbiPlate™ with M20 ChemSet™ Galvanised Anchor Stud installed with Reo502™ PLUS				
	Condition	Non-Cracked Concrete	Cracked Concrete	Seismic Cracked Concrete	
				C1	C2
$X_{v,cr,seis}$		1.00	0.70	0.30	0.30

Note: Seismic effect for C1 & C2 includes annular gap reduction factor of 0.5.

Table 4b - Concrete compressive strength effect, concrete edge shear, X_{vc}

Fixing System	OrbiPlate™ with M20 ChemSet™ Galvanised Anchor Stud installed with Reo502™ PLUS					
	f'_c (MPa)	20	25	32	40	50
	Condition					
X_{vc}		0.79	0.86	1.00	1.11	1.22

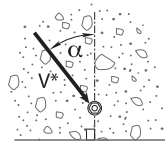

Load direction effect, conc. edge shear, X_{vd}

Table 4c - Load direction effect, concrete edge shear, X_{vd}

Angle, α°	0-55	60	70	80	90-180
X_{vd}	1.0	1.1	1.2	1.5	2.0

Table 4d - Concrete anchor spacing and edge distance effect, concrete edge shear, X_{ve}

For single anchor fastening X_{ve}

e/e_m	1.0	1.2	1.4	1.6	1.8	2.0	2.2	2.4	2.6	2.8	3.0	3.2
X_{ve}	1.00	1.31	1.66	2.02	2.41	2.83	3.26	3.72	4.19	4.69	5.20	5.72

For 2 anchors fastening X_{ve}

e/e_m	1.0	1.2	1.4	1.6	1.8	2.0	2.2	2.4	2.6	2.8	3.0	3.2
a/e_m												
1.0	0.67	0.84	1.03	1.22	1.43	1.65	1.88	2.12	2.36	2.62	2.89	3.16
1.5	0.75	0.93	1.12	1.33	1.54	1.77	2.00	2.25	2.50	2.76	3.03	3.31
2.0	0.83	1.02	1.22	1.43	1.65	1.89	2.12	2.38	2.63	2.90	3.18	3.46
2.5	0.92	1.11	1.32	1.54	1.77	2.00	2.25	2.50	2.77	3.04	3.32	3.61
3.0	1.00	1.20	1.42	1.64	1.88	2.12	2.37	2.63	2.90	3.18	3.46	3.76
3.5		1.30	1.52	1.75	1.99	2.24	2.50	2.76	3.04	3.32	3.61	3.91
4.0			1.62	1.86	2.10	2.36	2.62	2.89	3.17	3.46	3.75	4.05
4.5				1.96	2.21	2.47	2.74	3.02	3.31	3.60	3.90	4.20
5.0					2.33	2.59	2.87	3.15	3.44	3.74	4.04	4.35
5.5						2.71	2.99	3.28	3.71	4.02	4.33	4.65
6.0							2.83	3.11	3.41	3.71	4.02	4.33

For 3 anchors fastening and more

$$X_{ve} = \frac{3 \cdot e + a_1 + a_2 + a_3 + \dots + a_{n-1}}{3 \cdot n \cdot e_m} \cdot \sqrt{e/e_m}$$

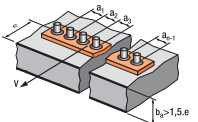
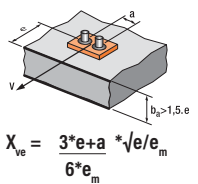
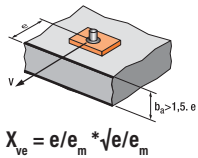

Strength Limit State Design / OrbiPlate™ with M20 ChemSet™ Anchor Stud with Reo 502™ PLUS

STEP 4

continued

Table 4e - Reduced characteristic ultimate concrete pryout capacity, ϕV_{ucp} (kN), $\phi = 1/1.5 = 0.67, f'_c = 32$ MPa

Anchor size, db	OrbiPlate™ with M20 ChemSet™ Galvanised Anchor Stud installed with Reo502™ PLUS			
	Non-Cracked Concrete	Cracked Concrete	Seismic C1	Seismic C2
100	83.0	58.1	21.8	14.7
150	156.8	106.7	32.6	22.1
170	177.7	128.7	37.0	25.0
200	209.1	156.8	43.5	29.4
280	292.7	219.6	60.9	41.2

Note: Seismic effect for C1 & C2 includes annular gap reduction factor of 0.5

Table 4f - Anchor at a corner effect, concrete edge shear, X_{vs}

Note: For $e_1/e_2 > 1.25, X_{vs} = 1.0$

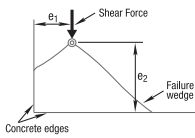

Edge distance, e_2 (mm)	50	60	75	125	200	300	400	600	900
50	0.86	0.77	0.67	0.52	0.44	0.39	0.37	0.35	0.33
60	0.97	0.86	0.75	0.57	0.47	0.41	0.38	0.36	0.34
75	1.00	1.00	0.86	0.64	0.51	0.44	0.41	0.37	0.35
125	1.00	1.00	1.00	0.86	0.65	0.53	0.48	0.42	0.38
200	1.00	1.00	1.00	1.00	0.86	0.67	0.58	0.49	0.42
300	1.00	1.00	1.00	1.00	1.00	0.86	0.72	0.58	0.49
400	1.00	1.00	1.00	1.00	1.00	1.00	0.86	0.67	0.55
500	1.00	1.00	1.00	1.00	1.00	1.00	1.00	0.77	0.61
600	1.00	1.00	1.00	1.00	1.00	1.00	1.00	0.86	0.67
900	1.00	1.00	1.00	1.00	1.00	1.00	1.00	1.00	0.86

CHECK POINT 4a

Design reduced ultimate concrete edge shear capacity, ϕV_{urc}

$$\phi V_{urc} = \phi V_{uc} * X_{v,cr,seis} * X_{vc} * X_{vd} * X_{ve} * X_{vs}$$

CHECK POINT 4b

Design reduced ultimate pryout capacity, ϕV_{urcp}

$$\phi V_{urcp} = \phi V_{ucp} * X_{n,cr,seis} * X_{nc} * X_{ne} * X_{na}$$

STEP 5

Verify anchor shear capacity - per anchor

Table 5a - Reduced characteristic ultimate steel shear capacity, ϕV_{us} (kN) where $\phi_v = 0.67$ and $\phi V_{us,seis}$ (kN) where $\phi_{vs} = 0.8$

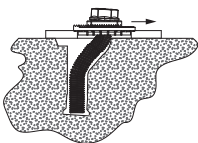

OrbiPlate™ with M20 ChemSet™ Galvanised Anchor Stud	Reduced Char, steel shear, ϕV_{us}		Reduced Char, seismic steel shear, $\phi V_{us,seis}$	
	Non-Cracked/Cracked Concrete		Seismic Category C1 & C2	
	Fixture Thickness (mm)		Fixture Thickness (mm)	
	6 to 16	16 > to 32	6 to 16	16 > to 32
ORB2020PIAGH	49.9	35.3	7.3	5.1

Note: Seismic effect for C1 & C2 includes annular gap reduction factor of 0.5

Strength Limit State Design / OrbiPlate™ M20 ChemSet™ Anchor Stud with Reo 502™ PLUS

CHECK POINT 5

Design reduced ultimate shear capacity, ϕV_{ur}

ϕV_{ur} = minimum of ϕV_{urc} , ϕV_{urcp} , ϕV_{us} or $\phi V_{us,seis}$

Check $V^* / \phi V_{ur} \leq 1$,

if not satisfied return to step 1

STEP 6 Combined loading and specification

CHECK POINT 6

Check

$N^* / \phi N_{ur} + V^* / \phi V_{ur} \leq 1.2$,

if not satisfied return to step 1

HOW TO SPECIFY

Ramset™ OrbiPlate™ M20 HDG POST INSTALLED ANCHOR KIT - ORB2020PIAGH
 ChemSet™ Reo502™ PLUS (AU) - RE0502P600

EXAMPLE

Ramset™ OrbiPlate™ M20 HDG POST INSTALLED ANCHOR KIT

Australia
 ChemSet™ Reo 502™ PLUS
 RE0502P600

Please refer to Ramset™ product guides for the full range of products available.

Note: It is the Design Engineer’s responsibility to ensure that the fixture plate is adequate for the design loads in accordance with AS 4100:2020 / AS 5216:2021 / NZS 3101:2006 (A3) Chapter 17

Important Disclaimer: Any engineering information or advice ("Information") provided by Ramset™ in this document is issued in accordance with a prescribed standard, published performance data or design software. It is the responsibility of the user to obtain its own independent engineering (or other) advice to assess the suitability of the Information for its own requirements. To the extent permitted by law, Ramset™ will not be liable to the recipient or any third party for any direct or indirect loss or liability arising out of, or in connection with, the Information.

Customer Service

Ramset™ Australia

Sales, Orders and Enquiries

Tel: 1300 780 063

Email: enquiry@ramset.com.au

Web: www.ramset.com.au

Website:

www.ramset.com.au



Keep up to date with
Ramset™ on our socials'



Ramset™ 1 Ramset Drive, Chirside Park 3116

Information in this document is correct at the time of printing. Readers should contact Ramset™ or consult Ramset™ detailed technical information to ensure product is suitable for intended use prior to purchase. ITW Australia Pty Ltd ABN 63 004 235 063 trading as Ramset™
© Copyright 2025.™ Trademarks of Cetram Pty. Ltd. Used under license by Ramset™

CB1523 PDL

